

## Sloping front cases

### Technical Drawing

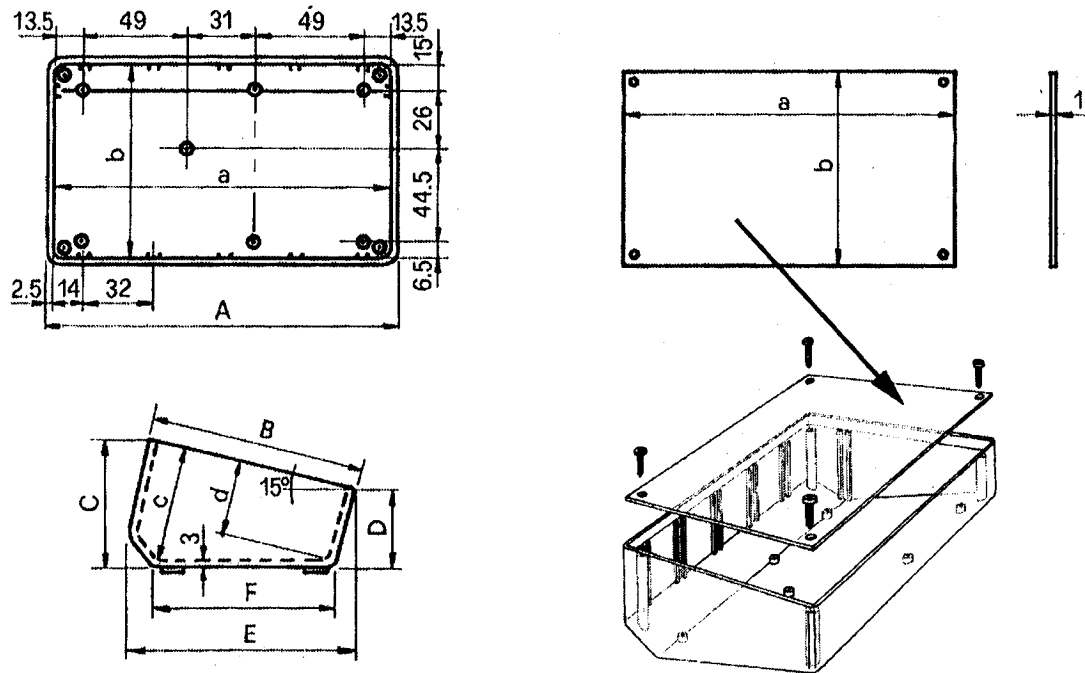

### Specification

Body Material : A.B.S. (Acrylonitrile-Butadiene-Styrene)  
 Lid Material : Anodised Aluminium

Dimensions										Weight (g)
External					Internal					
A	B	C	D	E	F	a	b	c	d	
161	95	60	39	103	80.5	156	90	55	37	157

	Units	Standards	ABS
<b>Mechanical Properties</b>			
Impact Resistance	KJ/m <sup>2</sup>	ISO 179 / DIN 53453	85
Notch Resistance	KJ/m <sup>2</sup>	ISO 179 / DIN 53453	11
Ball indentation hardness H.30	N/mm <sup>2</sup>	DIN 53456	100
Modulus of elasticity	KN/mm <sup>2</sup>	ISO 178 / DIN 53457	2.6
3.5% bending stress	N/mm <sup>2</sup>	ISO 178 / DIN 53452	73
Elongation at tear	%	DIN 53455	25
<b>Thermal Properties</b>			
Heat distortion temperature	°C	DIN 53458 / ISO 75-A / DIN 53461	90
Vicat softening temperature	°C	ISO 306 / DIN 53460	103
Cold distortion temperature	°C		-40
UL combustibility test	Fire classification	UL-Subject 94	HB
Thermal conductivity	W(K • M)	DIN 52612	0.19
<b>Electrical Properties</b>			
Tracking resistance KC/CTI	Stage	IEC 112 / DIN 53480	600
Specific volume resistivity	Ohm • cm	DIN53482 / VDE0303	10 <sup>15</sup>
Dielectric Strength	kV/mm	IEC 243 / DIN 53481	26
<b>Other Properties</b>			
Water absorption	%	DIN 53472 / DIN 53495	0.3